



## DF618 - Silverlink 600 Electric Counter-top Twin Tank Fryer - 2 Baskets - W 600 mm - 2 x 9.0 kW

The Silverlink 600 Electric Twin Tank Counter Top Fryer not only provides greater versatility, but also increased power capable of delivering 132kg of chips per hour.

- ✓ Two independently operated fryer tanks for greater versatility, increased power delivers 132kg of chips per hour
- ✓ Front mounted controls for safety
- ✓ Hinged elements to give easy access during cleaning
- ✓ Cool zone collects cooking debris - gives cleaner cooking results and saves money by prolonging the life of the oil
- ✓ Thermostatically controlled to give accurate cooking temperatures throughout cooking. Fail-safe top temperature cut out ensures safe operation.
- ✓ Fully moulded 304 stainless steel tank and heavy duty nickel plated baskets for the most demanding of operations
- ✓ Front drain off tap for easy removal of cooking oil

### Specifications

#### Summary

<b>Range Name</b>	Silverlink 600
<b>Power Type</b>	Electric
<b>Unit Type</b>	Counter-top
<b>Available in UK Only</b>	No
<b>UK Warranty</b>	2 Years Parts and Labour Warranty
<b>Export Warranty</b>	Contact your local dealer
<b>GTIN Code</b>	5056105104650

#### Power and Performance

<b>Total Power kW</b>	2 x 9.0
<b>Temperature Range °C</b>	130 - 190
<b>IP Rating</b>	IP33
<b>Temperature Control</b>	Mechanical

#### Key Specifications

<b>Capacity Litres</b>	2 x 9.0
<b>Number of Baskets</b>	2
<b>Number of Tanks</b>	2
<b>Gravity Filtration</b>	No
<b>Pumped Filtration</b>	No
<b>Drain Location</b>	Front-mounted

#### Weights and Dimensions

<b>Unit Height (External) mm</b>	330
<b>Unit Width (External) mm</b>	600
<b>Unit Depth (External) mm</b>	632
<b>Net Weight Kg</b>	27

#### Supply Connections

<b>Requires Installation</b>	Yes
<b>Requires Electrical Supply</b>	Yes
<b>UK 3 Pin Plug</b>	No
<b>Requires Hardwiring</b>	Yes
<b>Electrical Supply Rating Watts</b>	2 x 9,000
<b>Single Phase Amps</b>	2 x 39.0
<b>Single Phase Voltage</b>	230
<b>Three Phase Amps</b>	L1=2 x 13.0 ; L2=2 x 13.0 ; L3=2 x 13.0
<b>Three Phase Voltage</b>	400

#### Shipping

<b>Packed Weight Kg</b>	33
<b>Packed Height cm</b>	49.5
<b>Packed Width cm</b>	70
<b>Packed Depth cm</b>	70

### Available Accessories

<b>BA96</b>	BASKET SPUN DFSMALL
<b>CC6</b>	Silverlink 600 Free-standing Ambient Open-Top Pedestal with Doors - W 600 mm
<b>CN6</b>	Silverlink 600 Free-standing Ambient Open-Top Pedestal without Doors - W 600 mm
<b>HC6</b>	Silverlink 600 Free-standing Heated Open-Top Pedestal with Doors - W 600 mm - 0.5 kW

**Available Accessories**

- HCL6** Silverlink 600 Free-standing Heated Pedestal with Legs and Doors - W 600 mm - 0.5 kW
- SLS6** Silverlink 600 Free-standing Floor Stand - for units W 600 mm

**Technical Picture**

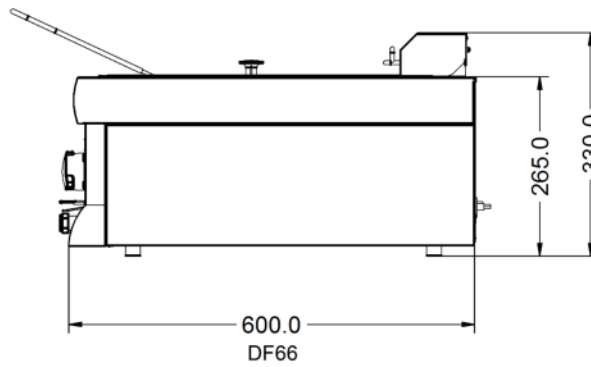
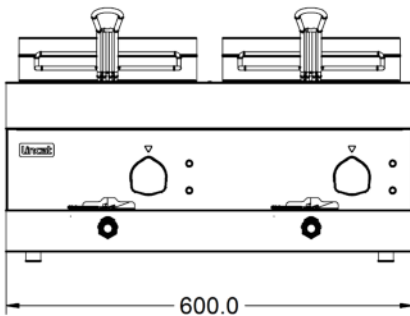
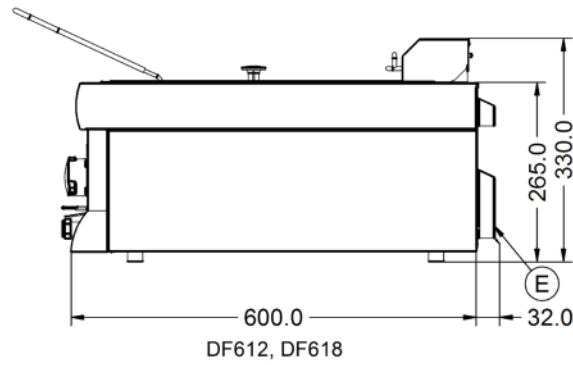
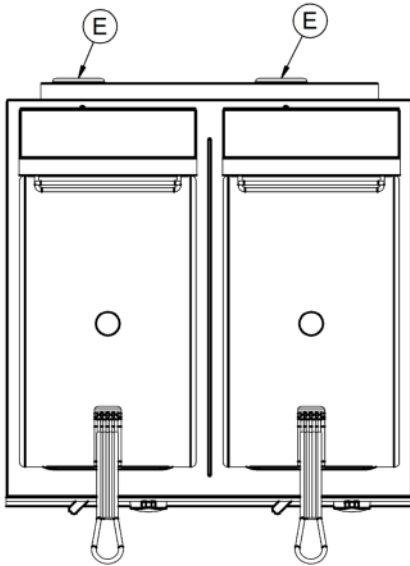



**Lincat Limited**

Whisby Road,  
Lincoln, LN6 3QZ,  
United Kingdom

**Company No:** 2175448

A member company of



**Customer Care**

**Tel:** +44 1522 875500  
**Email:** care@lincat.co.uk

**Export Customers**

**Tel:** +44 1522 503250  
**Email:** export@lincat.co.uk

**Opening Hours**

**Monday – Friday:**  
8.30am – 5pm